

Vessel Data Information Form

ATEX Protection Concept.



For ATEX to produce an accurate Quotation, the following information is required for any particular vessel.

Single Leg Bucket Elevators.

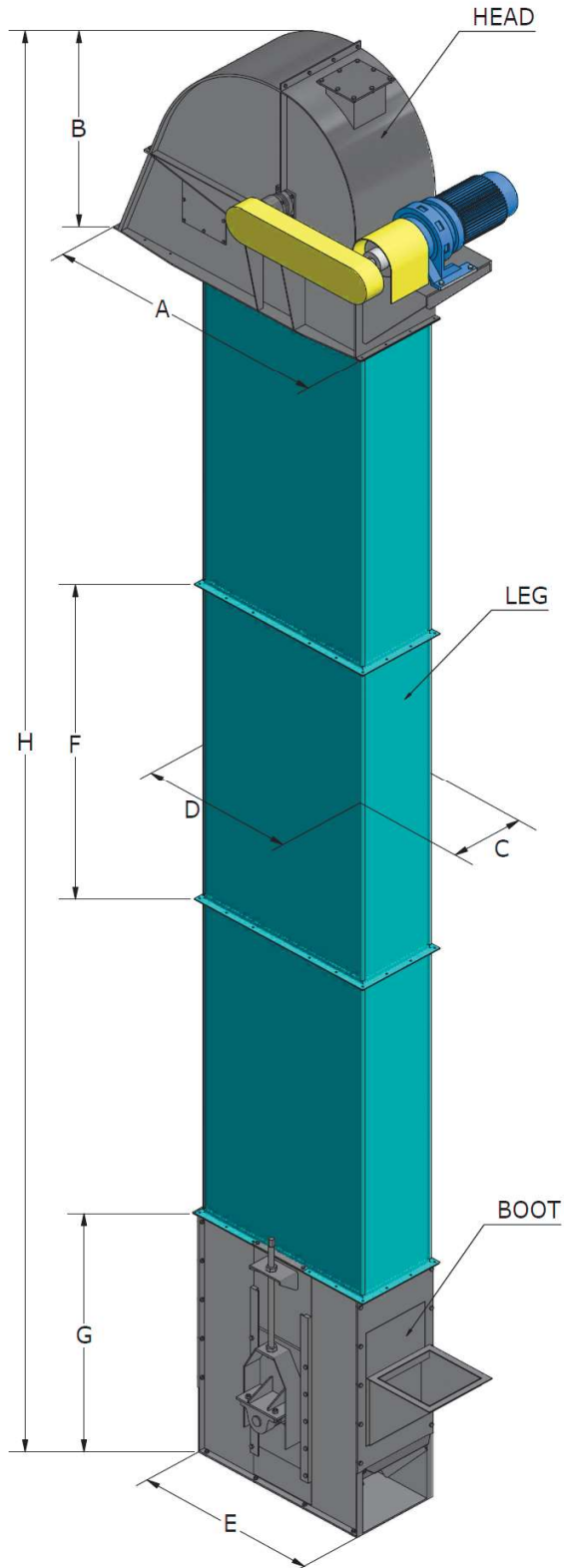

Dimensions

H	mm
B	mm
F	mm
G	mm
A	mm
C	mm
D	mm
E	mm

Product Characteristics

Name of Product	
KST - value	bar.m/s
Pmax	bar

Vessel Data

Design Pressure (Pred)	barg
Vent Duct	Yes / No
Bucket Spacing < 280 mm	Yes / No
Bucket Material	Plastic / Metal
Bucket Elevator Booth below ground floor level	Yes / No
If Yes, How many meters below ground	m

Double Leg Bucket Elevators.

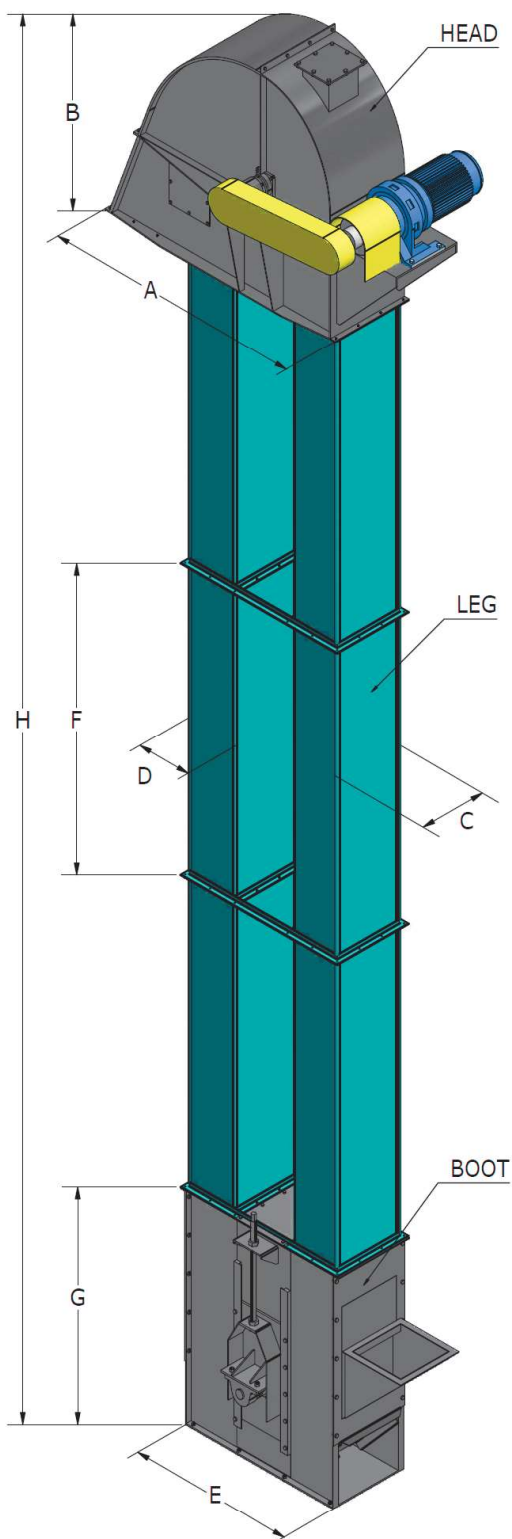

Dimensions

H	mm
B	mm
F	mm
G	mm
A	mm
C	mm
D	mm
E	mm

Product Characteristics

Name of Product	
KST - value	bar.m/s
Pmax	bar

Vessel Data

Design Pressure (Pred)	barg
Vent Duct	Yes / No
Bucket Spacing < 280 mm	Yes / No
Bucket Material	Plastic / Metal
Bucket Elevator Booth below ground floor level	Yes / No
If Yes, How many meters below ground	m